

CCNA 200-301, Volume 2

Chapter 11 Quality of Service (QoS)

Reben Kurda
ISE/EPU

Objectives

- Explain the forwarding per-hop behavior (PHB) for QoS such as classification, marking, queuing, congestion, policing, shaping

Bandwidth, Delay, Jitter, and Loss

- **Bandwidth:** The speed of a link, in bits per second
- **Delay:** One-way delay or round-trip delay between a source and destination
- **Jitter:** The variation in one-way delay between consecutive packets sent by the same source
- **Loss:** The number of loss messages, usually as a percentage of packets sent

Disproportionate Packet/Byte Volumes with HTTP Traffic

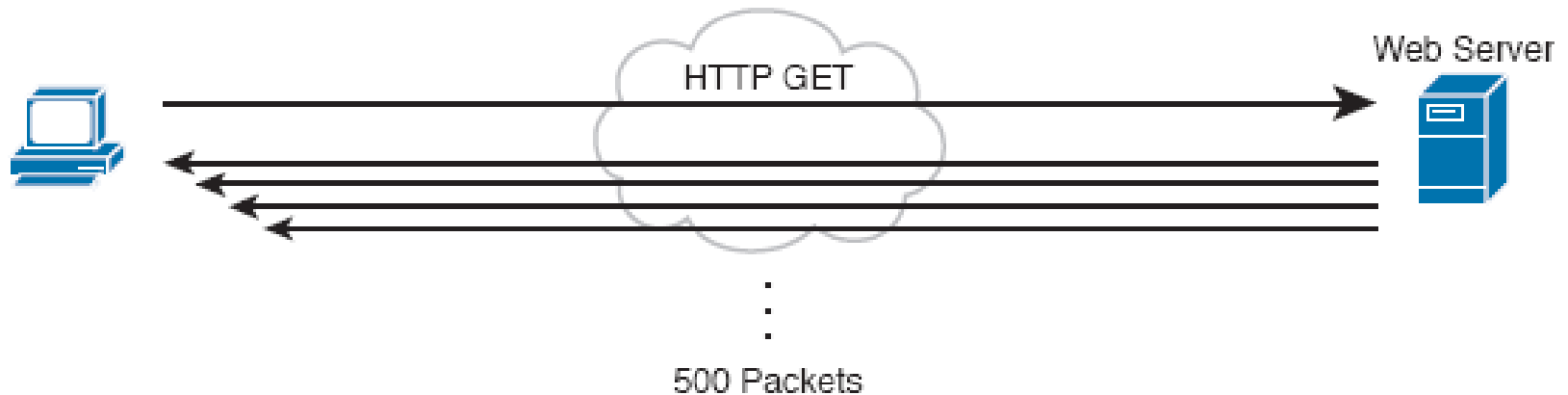

Creating VoIP Packets with an IP Phone and a G.711 Codec

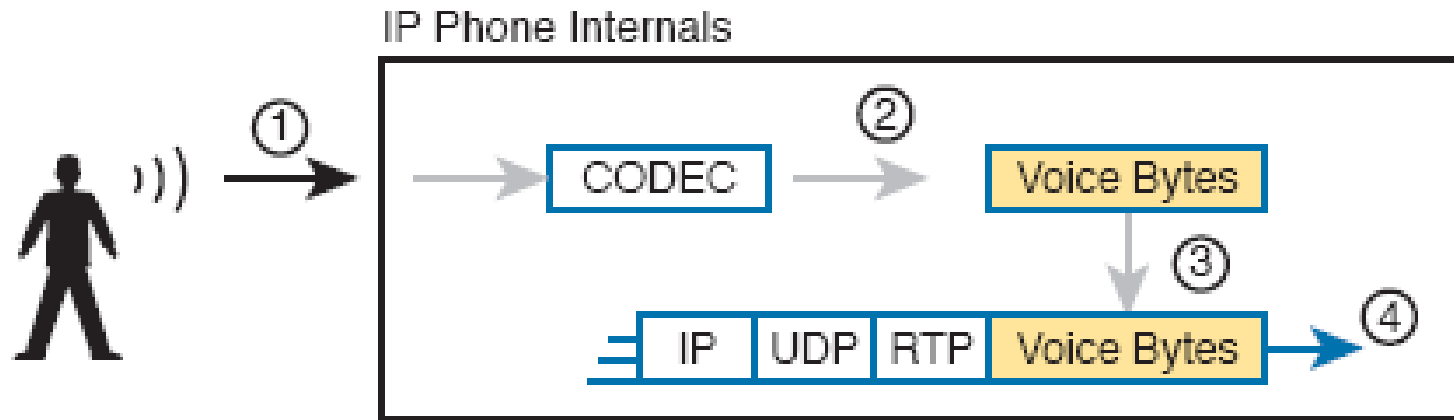

Classification for Queuing in a Router

Router Internals

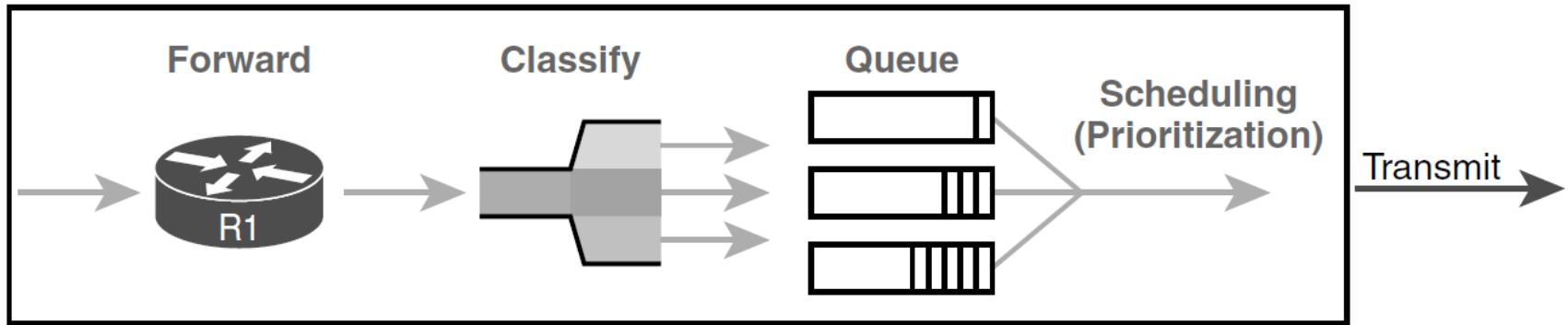

Systematic Classification and Marking for the Enterprise

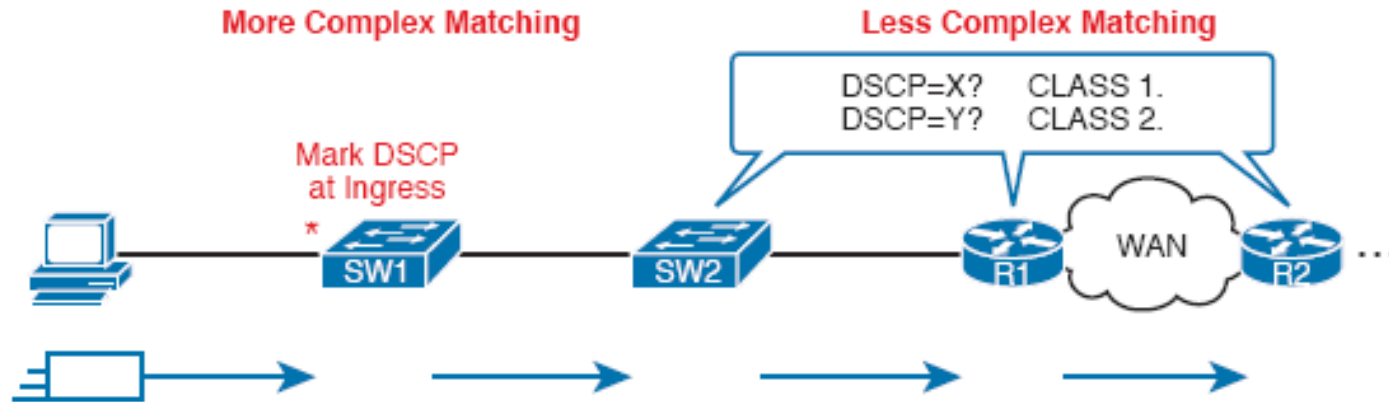

Classification with Five Fields Used by Extended ACLs

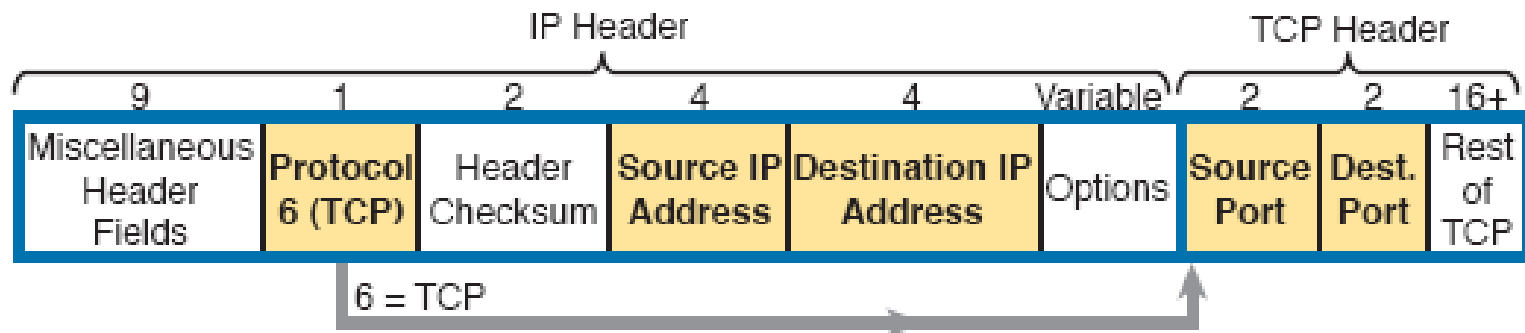

Example of the Many NBAR2 Matchable Applications

```
R1#(config)# class-map matchingexample
R1(config-cmap)# match protocol attribute category voice-and-video ?
! output heavily edited for length
amazon-instant-video      VOD service by Amazon
cisco-ip-camera           Cisco video surveillance camera
cisco-phone               Cisco IP Phones and PC-based Unified Communicators
espn-video                 ESPN related websites and mobile applications video
facetime                  Facetime video calling software
! Output snipped.
```

IP Precedence and Differentiated Services Code Point Fields

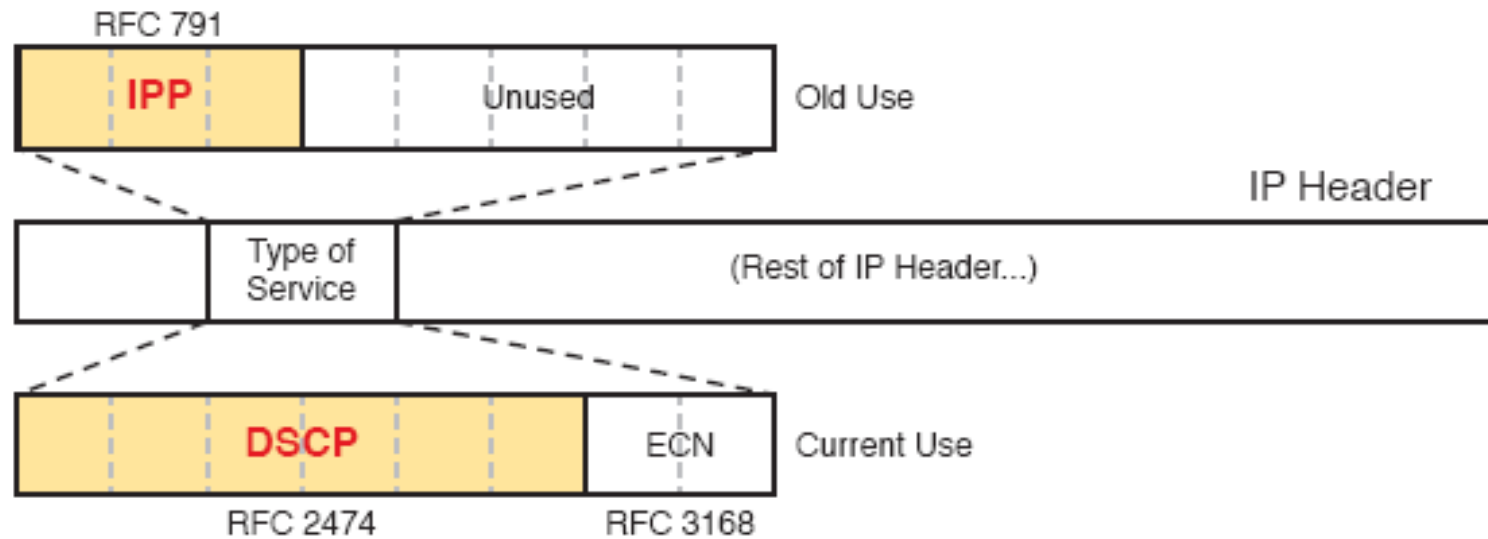

Class of Service Field in 802.1Q/p Header

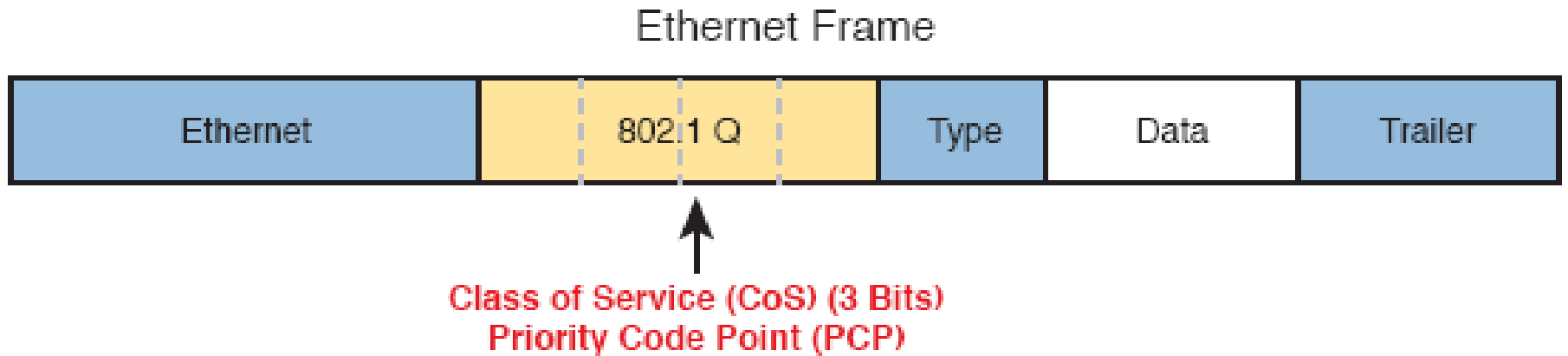

Useful Life of CoS Marketing

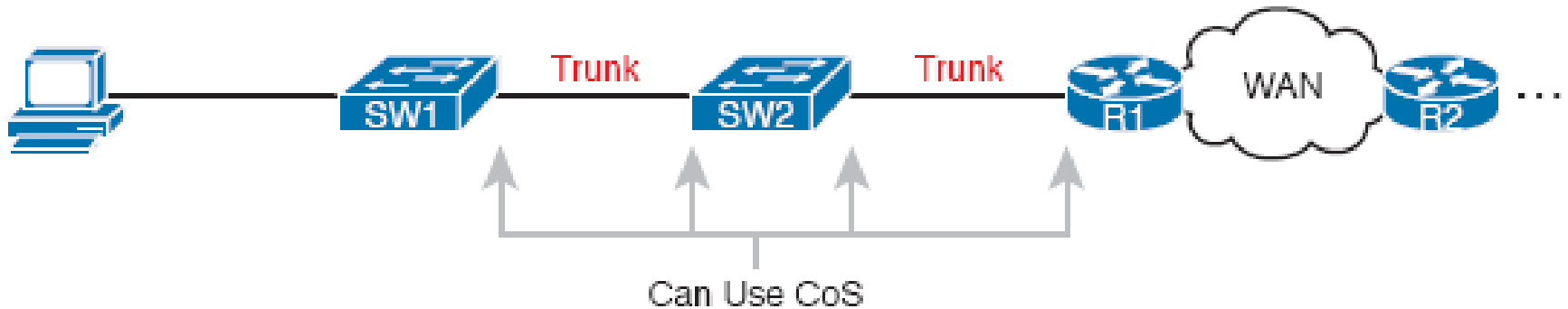

Marking Fields

Field Name	Header(s)	Length (bits)	Where Used
DSCP	IPv4, IPv6	6	End-to-end packet
IPP	IPv4, IPv6	3	End-to-end packet
CoS	802.1Q	3	Over VLAN Trunk
TID	802.11	3	Over Wi-Fi
EXP	MPLS Label	3	Over MPLS WAN

Defining Trust Boundaries—PC

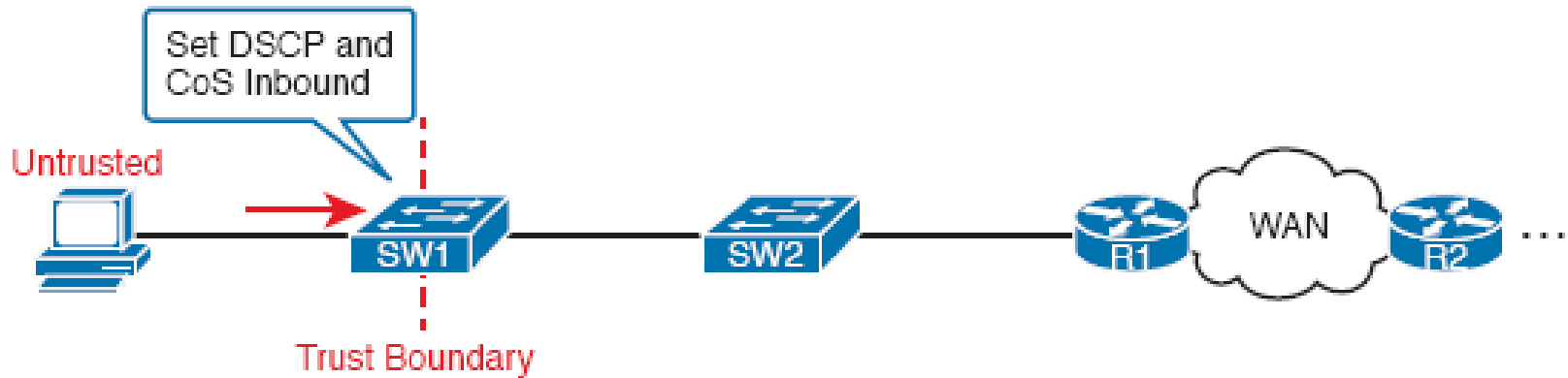

Defining Trust Boundaries—IP Phone

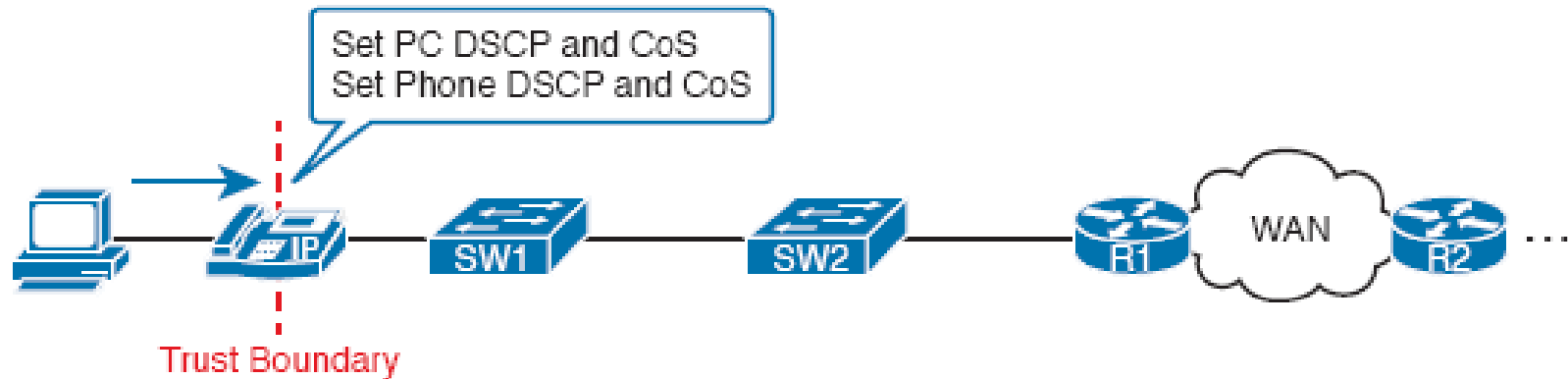

Differentiated Services Assured Forwarding Values and Meaning

Best Drop ← Worst Drop

Best Queue	AF41 (34)	AF42 (36)	AF43 (38)
	AF31 (26)	AF32 (28)	AF33 (30)
	AF21 (18)	AF22 (20)	AF23 (22)
Worst Queue	AF11 (10)	AF12 (12)	AF13 (14)

Class Selector

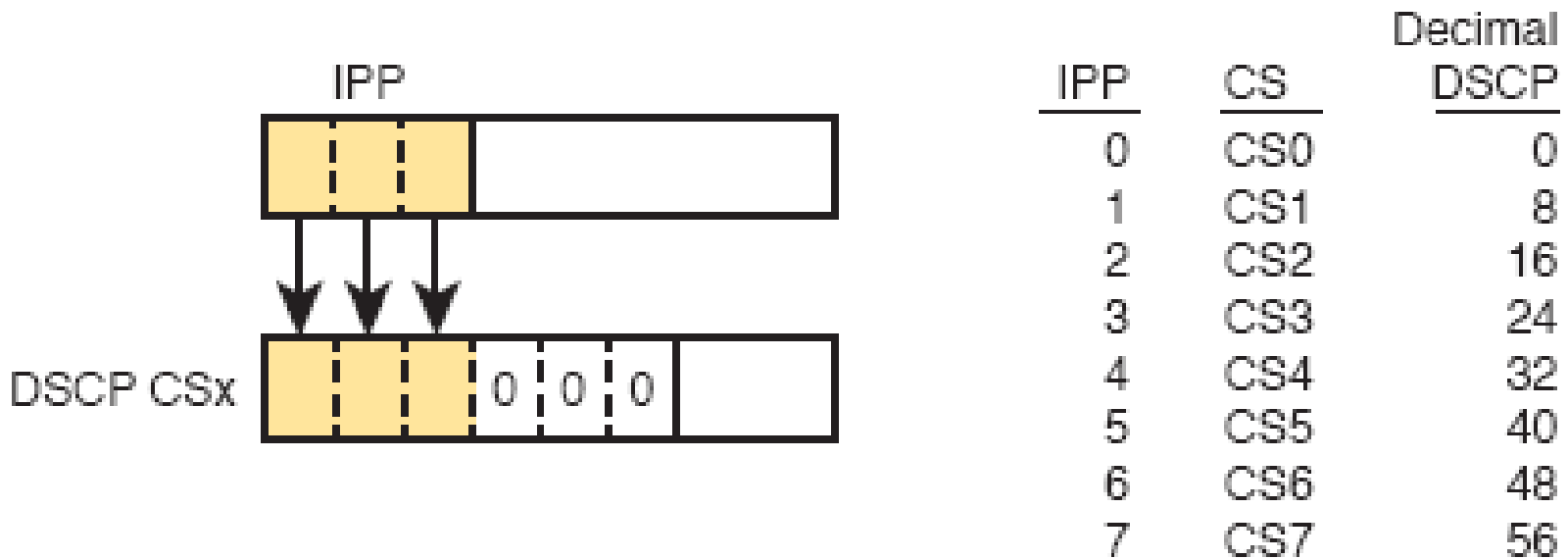

Output Queuing in a Router: Last Output Action Before Transmission

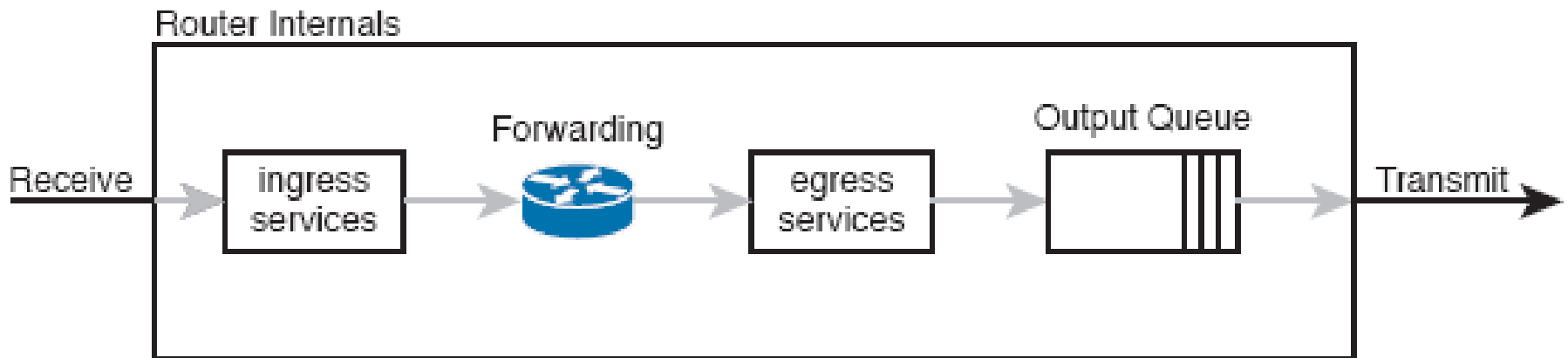

Queuing Components

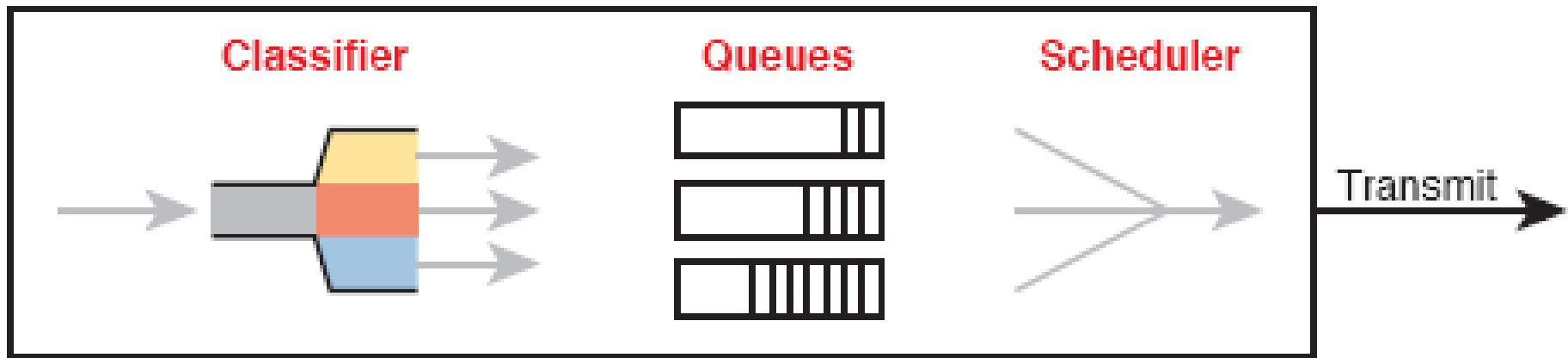

CBWFQ Round-Robin Scheduling

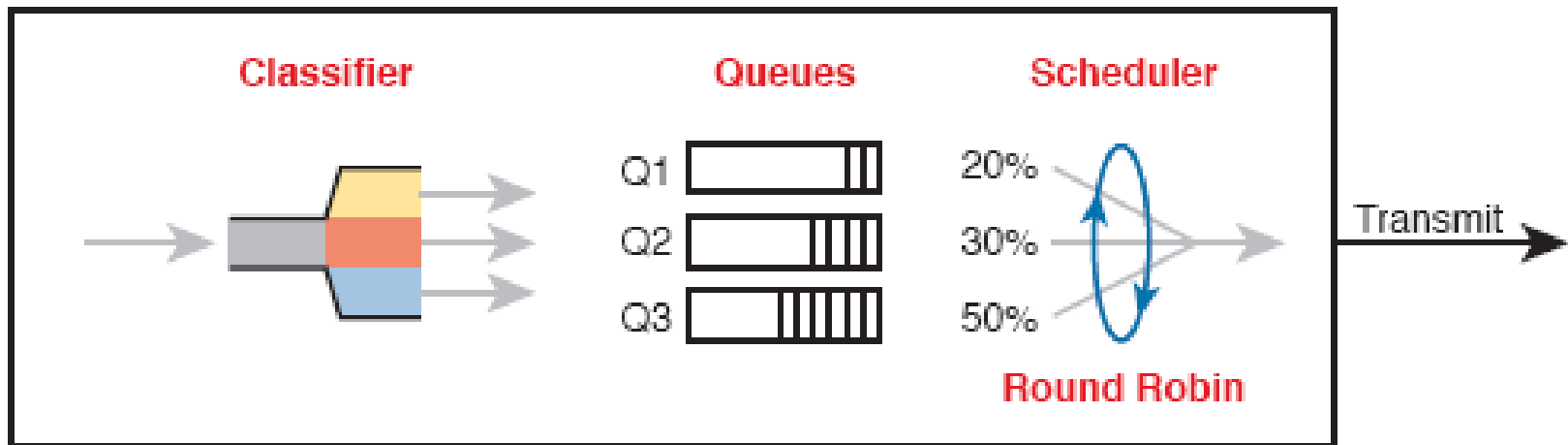

QoS Requirements for a VoIP Call per Cisco Voice Design Guide

Bandwidth/call	One-way Delay (max)	Jitter (max)	Loss (max)
30-320 Kbps	150 ms	30 ms	<1%

Round Robin Not Good for Voice Delay (Latency) and Jitter

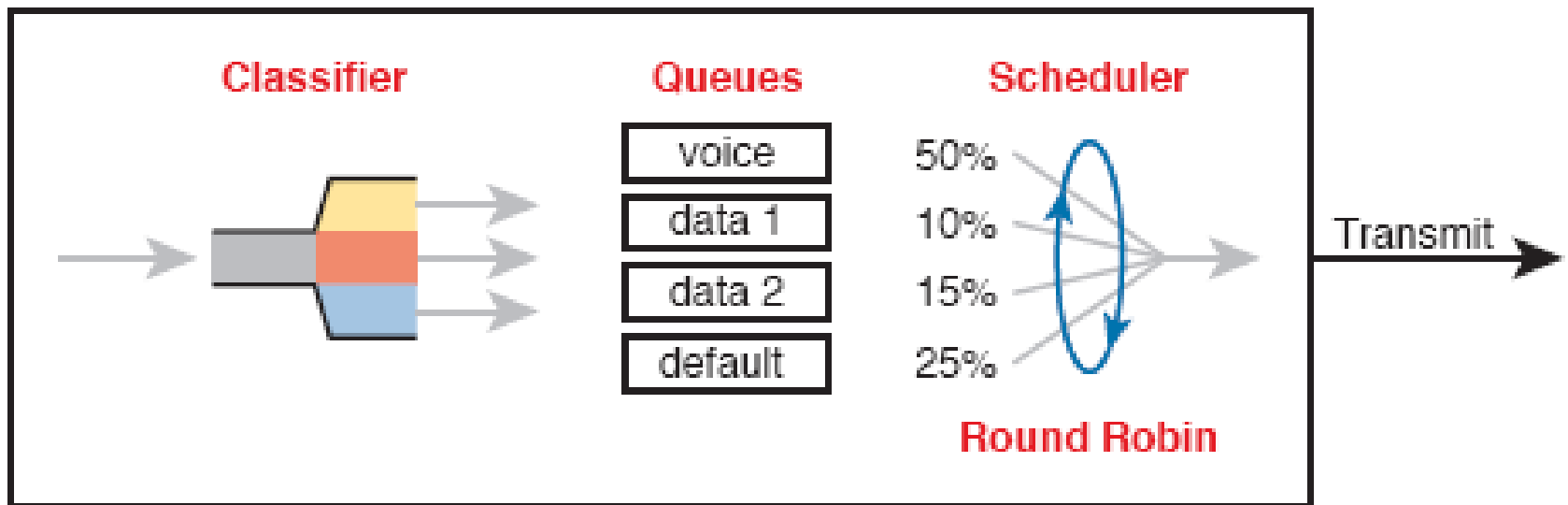

LLQ Always Schedules Voice Packet Next

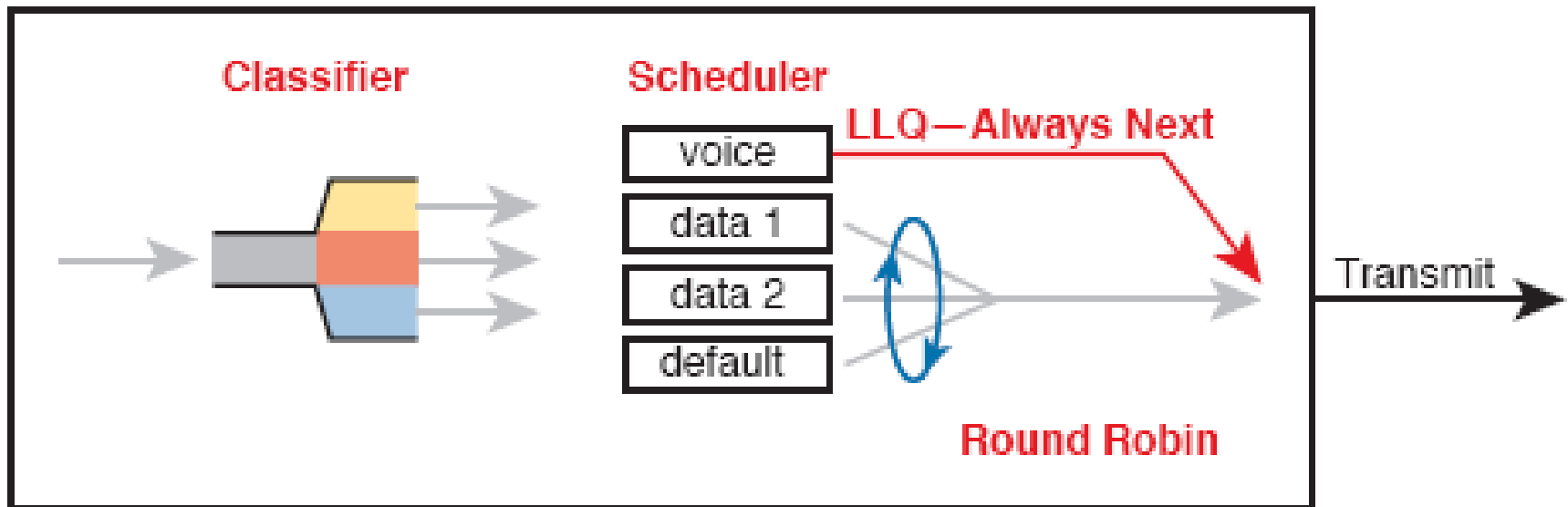

Prioritization Strategy for Data, Voice, and Video

1. Use a round robin queuing method like CBWFQ for data classes and for noninteractive voice and video.
2. If faced with too little bandwidth compared to the typical amount of traffic, give data classes that support business-critical applications much more guaranteed bandwidth than is given to less important data classes.
3. Use a priority queue with LLQ scheduling for interactive voice and video, to achieve low delay, jitter, and loss.

Prioritization Strategy for Data, Voice, and Video (continued)

4. Put voice in a separate queue from video, so that the policing function applies separately to each.
5. Define enough bandwidth for each priority queue so that the built-in policer should not discard any messages from the priority queues.
6. Use Call Admission Control (CAC) tools to avoid adding too much voice or video to the network, which would trigger the policer function.

Effect of a Policer and Shaper on an Offered Traffic Load

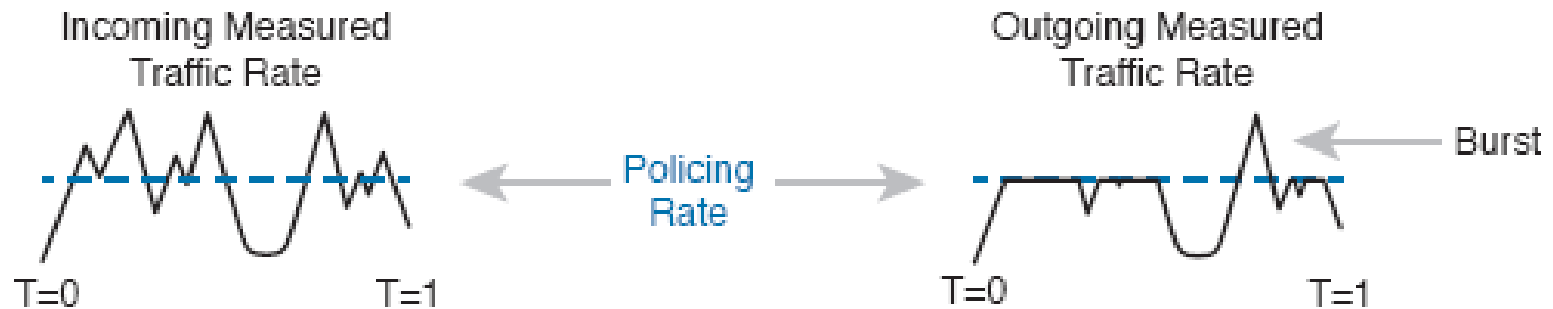

Ethernet WAN: Link Speed Versus CIR

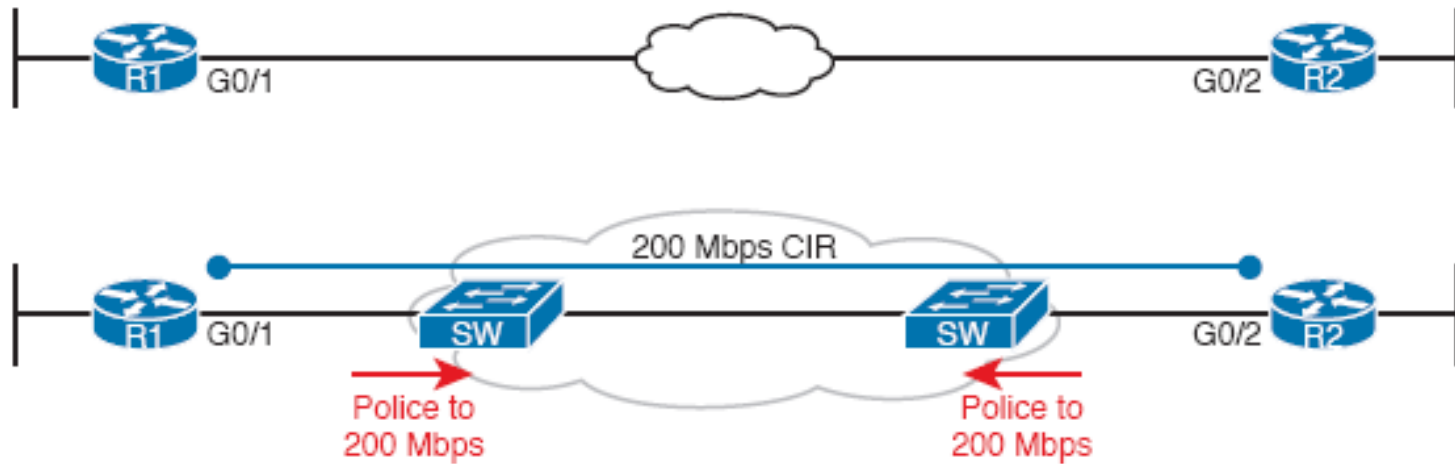

Shaping Queues: Scheduling with LLQ and CBWFQ

Router Internals

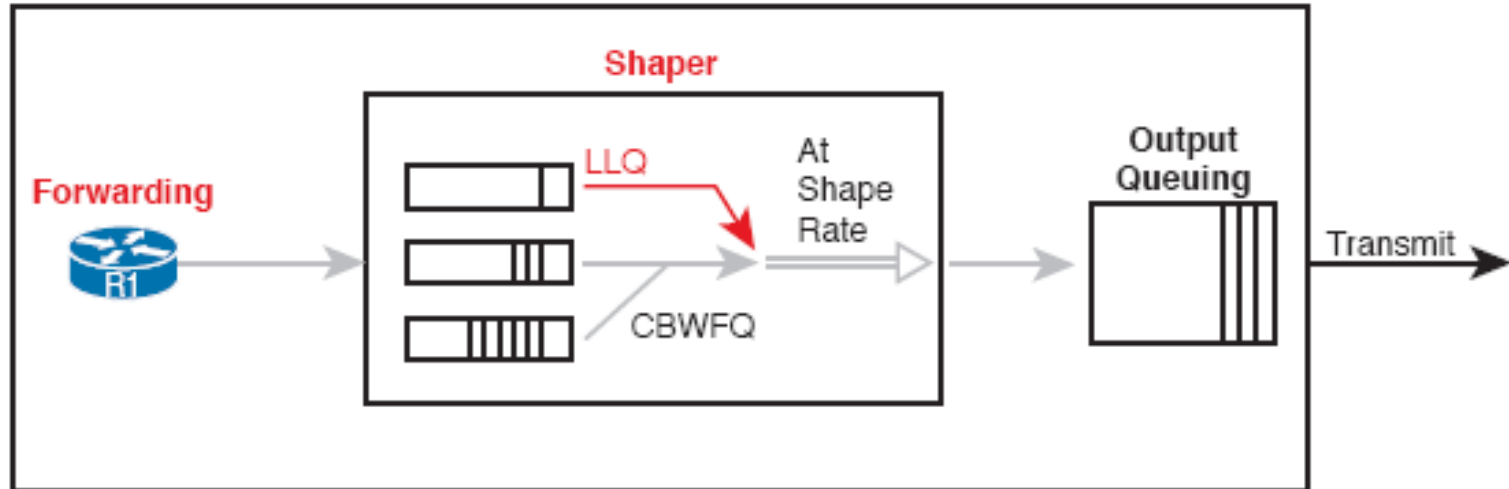

One Second (1000 ms) Shaping Time Interval, Shaping at 20 Percent of Line Rate

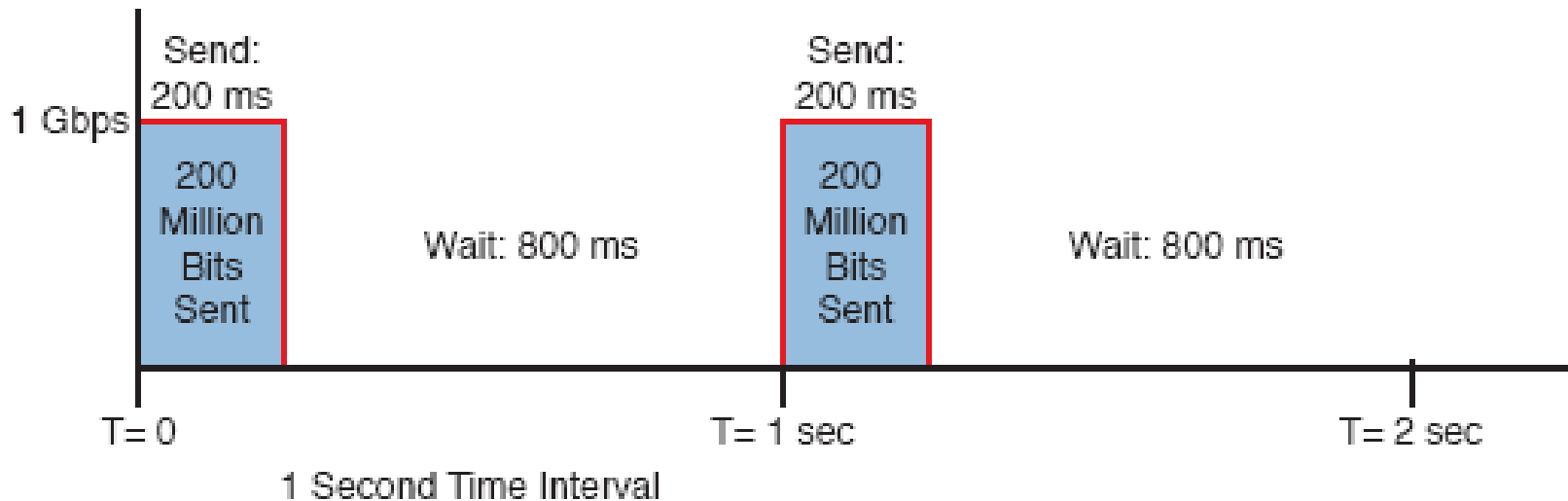

Tail Drop Concepts with Three Different Scenarios

① Little Congestion

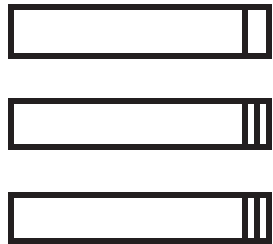

② Medium Congestion

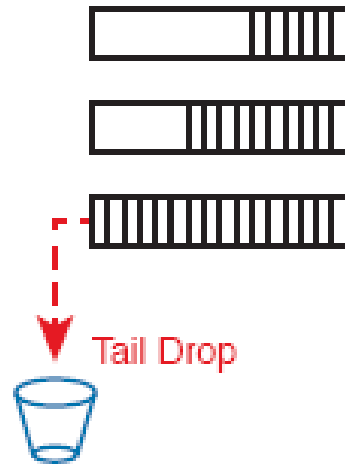

③ Much Congestion

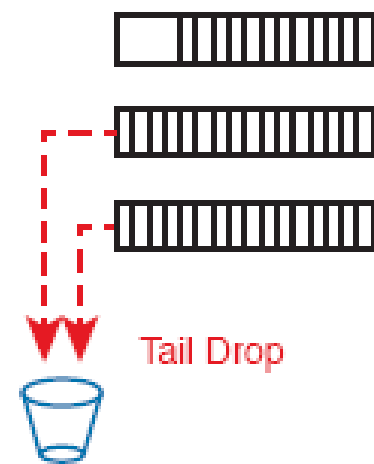

Mechanisms of Congestion Avoidance

